

SF3838F85CQ01 Datasheet

Infrared Emitter











3838 Series (850nm) - 50°



Applications

-  Security System
-  Automotive

Features

-  Package: clear silicone
-  Corrosion robustness class: 3B
-  ESD: 2KV (HBM : MIL STD 883 Class 2)
-  IR light source with high efficiency
-  Dual junction emitter
-  Qualifications: AEC-Q102 Qualified
-  Low thermal resistance (Max. 9 K/W)
-  Peak wavelength 850 nm
-  Optimized for high current pulse operation
-  RoHS 2.0 and REACH compliant
-  MSL 2 qualified according to J-STD 020

SF3838F85CQ01

Dimensional Drawing

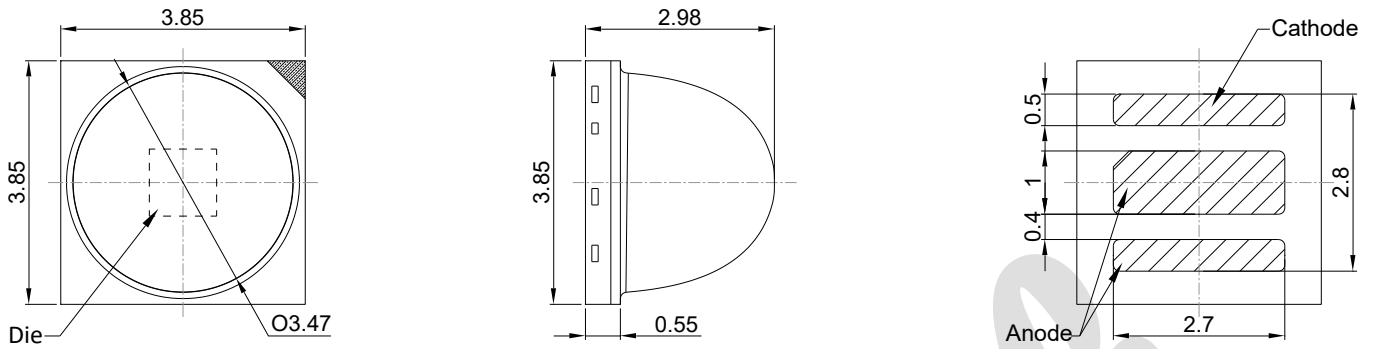

1. Dimensions are in millimeters.
2. General tolerance is $\pm 0.05\text{mm}$.

Recommended Solder Pad

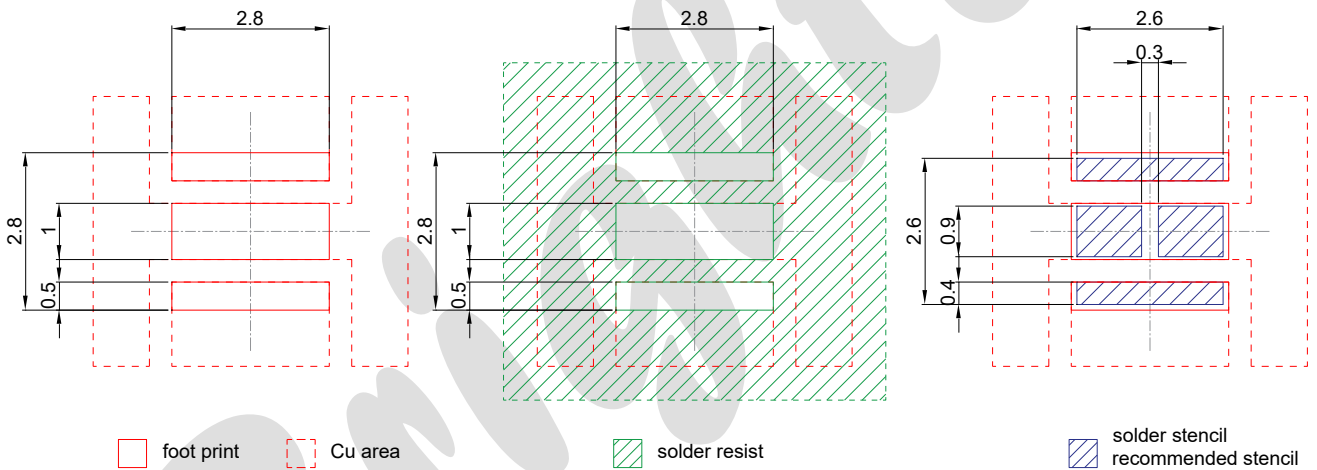

foot print

Cu area

solder resist

solder stencil
recommended stencil

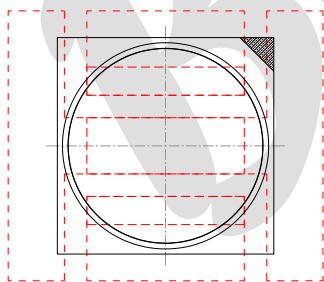

Component Location on Pad

SF3838F85CQ01

Maximum Ratings

T_A : 25 °C

Parameter	Symbol	Rating
Forward current	I _F	max. 1500 mA
Power consumption	P _{tot}	max. 5.7 W
Pulse forward current	I _{PF}	max. 5 A
Reverse voltage	V _R	max. 5 V
Junction temperature	T _j	max. 145 °C
Operating temperature	T _{op}	min. -40 °C
		max. 125 °C
Storage temperature	T _{stg}	min. -40 °C
		max. 125 °C
Soldering temperature	T _{sol}	max. 260 °C
Thermal resistance junction	R _{th}	typ. 4.5 K/W
		max. 9 K/W
ESD withstand voltage (HBM : MIL STD 883 Class 2)	V _{ESD}	max. 2 kV

1. For other ambient, limited setting of current will depend on de-rating curves.
2. When drive on maximum current, Junction temperature must be kept below 145°C.

SF3838F85CQ01

Characteristics

I_F : 1A | t_p : 10 ms | T_A : 25°C

Parameter	Symbol	Values
Peak wavelength	λ_p	typ. 850 nm
Spectral bandwidth	$\Delta\lambda$	typ. 35 nm
View angle	$2\theta_{1/2}$	typ. 50 °
Total radiant power $I_F = 1 \text{ A}; t_p = 100\mu\text{s}$	Φ_e	min. 1100 mW typ. 1360 mW max. 1600 mW
Total radiant power $I_F = 1.5 \text{ A}; t_p = 10\text{ms}$	Φ_e	min. 1700 mW typ. 1950 mW max. 2200 mW
Radiant intensity	I_E	min. 850 mW/sr typ. 1050 mW/sr max. 1250 mW/sr
Radiant intensity $I_F = 1.5 \text{ A}; t_p = 10\text{ms}$	I_E	min. 1300 mW/sr typ. 1500 mW/sr max. 1700 mW/sr
Forward voltage $I_F = 1 \text{ A}; t_p = 100\mu\text{s}$	V_F	min. 2.9 V typ. 3.25 V max. 3.6 V
Forward voltage $I_F = 1.5 \text{ A}; t_p = 100\mu\text{s}$	V_F	min. 3.0 V typ. 3.4 V max. 3.8 V
Forward voltage $I_F = 5 \text{ A}; t_p = 100 \mu\text{s}$	V_F	typ. 4.4 V max. 5.0 V
Reverse current ($V_R=5\text{V}$)	I_R	max. 10 μA

SF3838F85CQ01

Brightness Groups

Total radiant power $I_F : 1A$ | $t_p : 10$ ms

Group	min. Φ_e	max. Φ_e
PB1A	1100 mW	1300 mW
PB3A	1300 mW	1500 mW
PB5	1500 mW	1600 mW

Forward voltage $I_F : 1A$ | $t_p : 10$ ms

Group	min. V_F	max. V_F
KN	2.8 V	3.6 V

Peak wavelength $I_F : 1A$ | $t_p : 10$ ms

Group	min. λ_p	max. λ_p
F3	840 nm	870 nm

SF3838F85CQ01

Typical Electrical Optical Characteristics Curves

Radiation Characteristics(L=0)

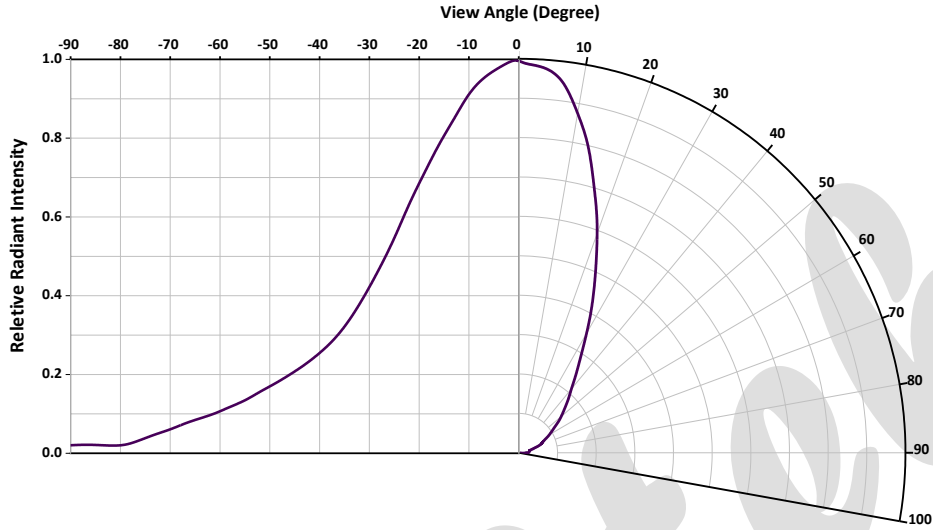

Radiant Intensity

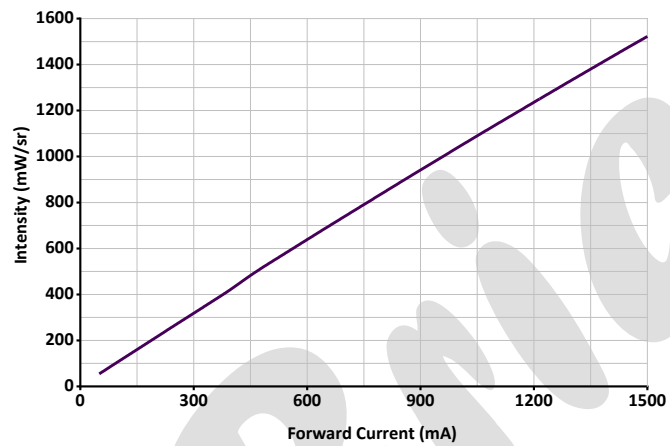

Total radiant power

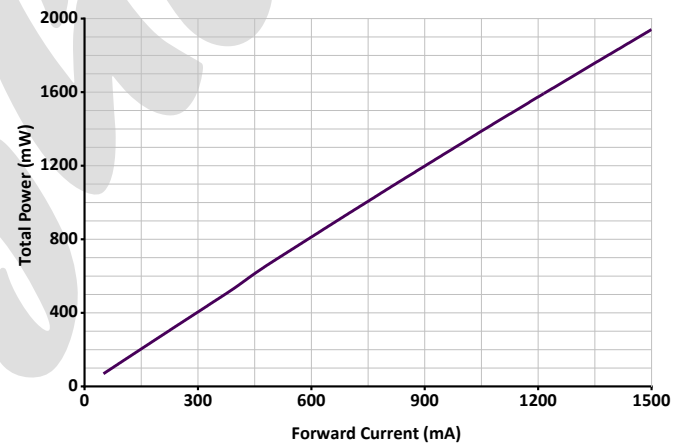

Forward current

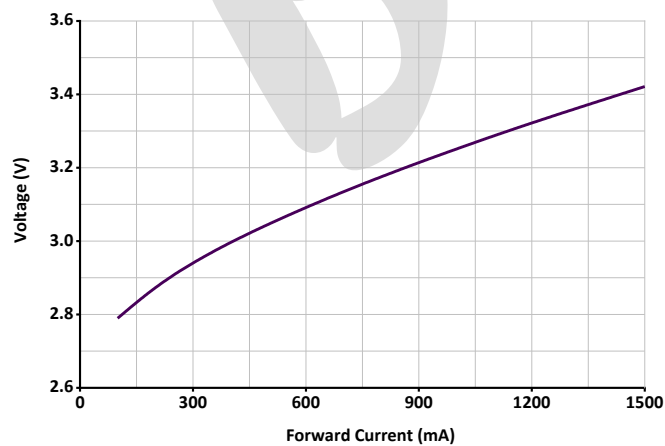

Relative Spectral Emission

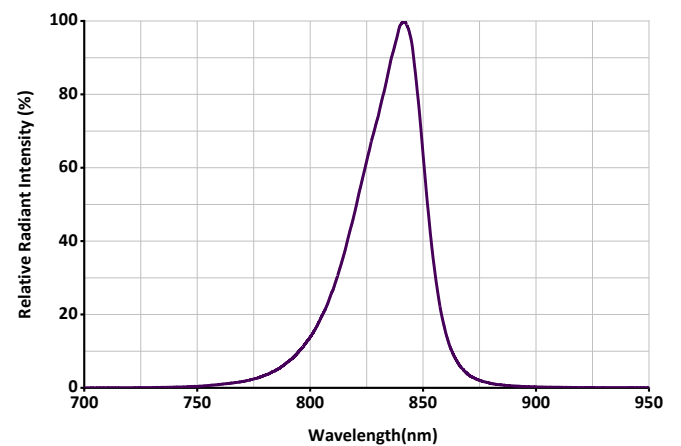

SF3838F85CQ01

Permissible Forward Current

$$I_{F,max} = f(T_S); R_{th_{j_s}} = 9K/W$$

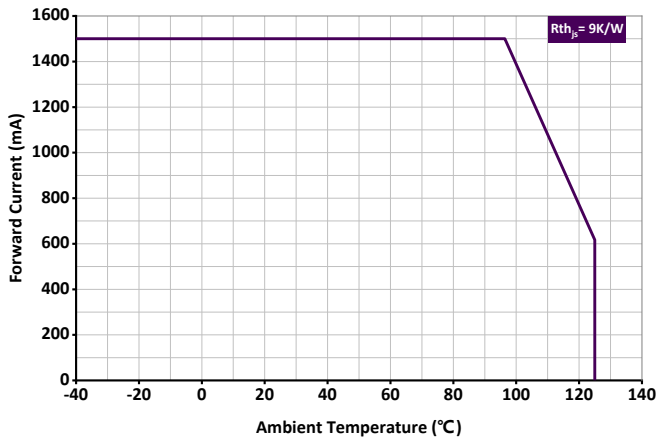

Permissible Pulse Handling Capability

$$I_F = f(t_p); D = \text{Duty cycle}; T_S = 85^\circ\text{C}$$

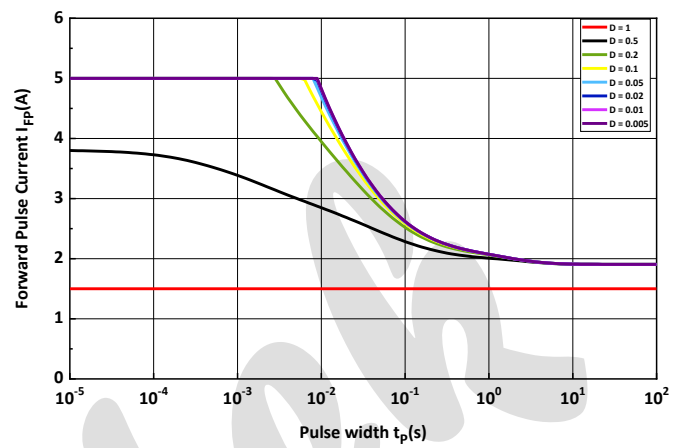

SF3838F85CQ01

Reflow Soldering Profile

Product complies to MSL Level 2 acc. to JEDEC J-STD-020E

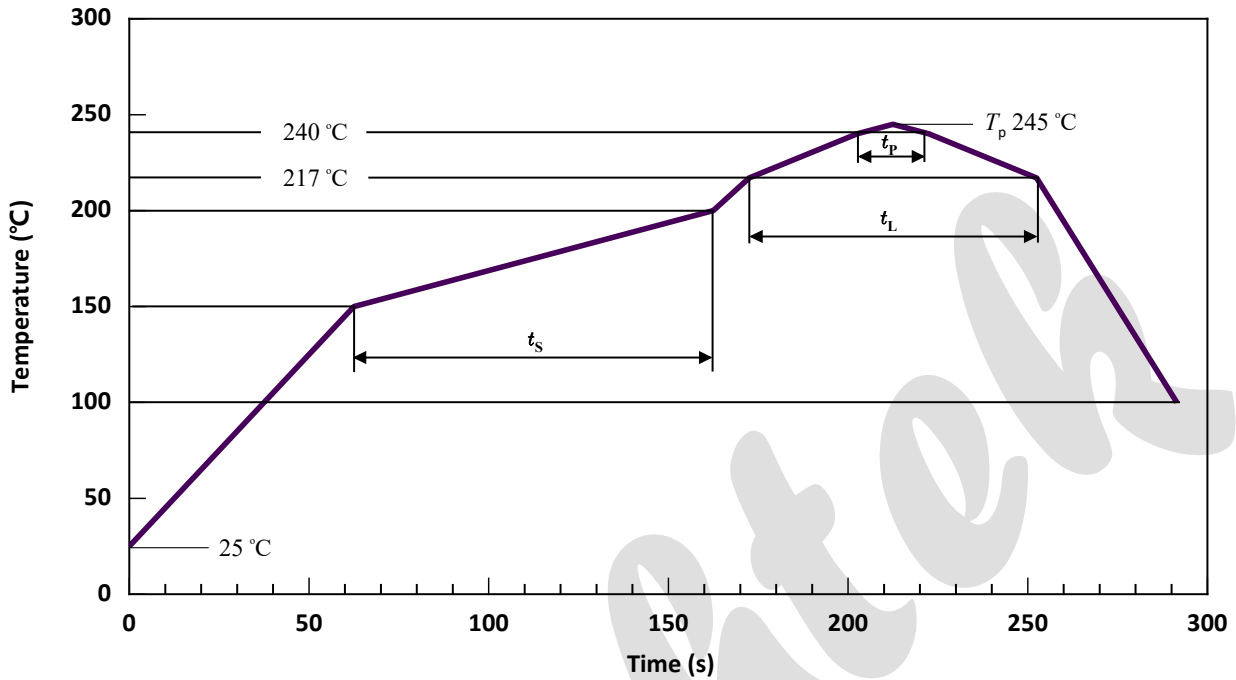

Profile Feature	Symbol	Pb-Free (SnAgCu) Assembly			Unit
		Minimum	Recommendation	Maximum	
Ramp-up rate to preheat 25 °C to 150 °C			2	3	K/s
Time t_s T_{Smin} to T_{Smax}	t_s	60	100	120	s
Ramp-up rate to peak T_{Smax} to T_P			2	3	K/s
Liquidus temperature	T_L		217		°C
Time above liquidus temperature	t_L		80	100	s
Peak temperature	T_P		245	260	°C
Time within 5 °C of the specified peak temperature $T_P - 5$ K	T_P	10	20	30	s
Ramp-down Rate T_P to 100 °C			3	4	K/s
Time 25 °C to T_P				480	s

1. Do not stress the silicone resin while it is exposed to high temperature.
2. The reflow process should not exceed 2 times.

SF3838F85CQ01

Dimensions of Tape

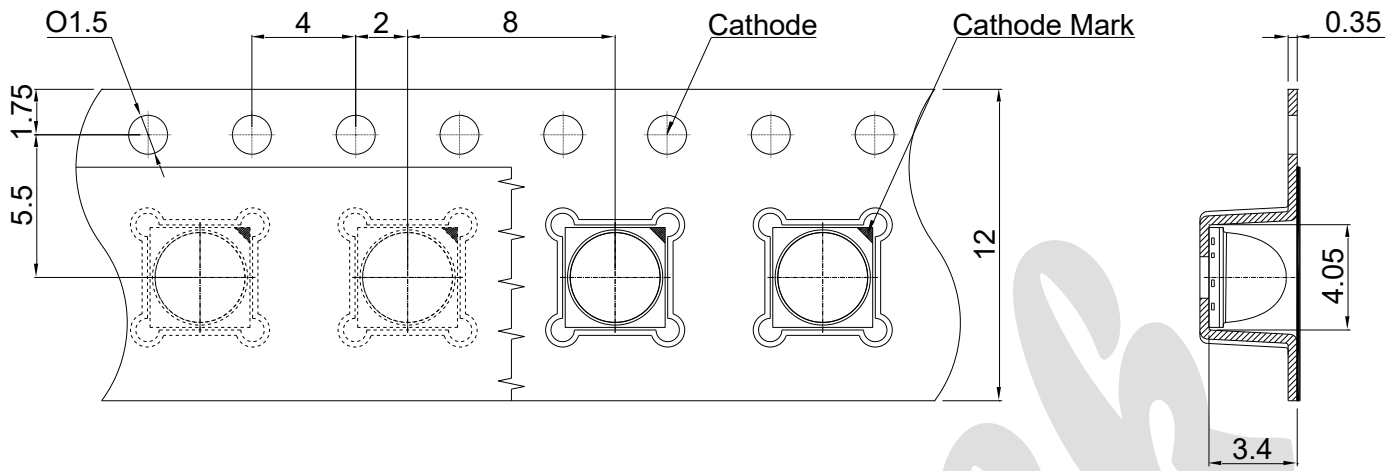

1. Dimensions are in millimeters.
2. General tolerance is ± 0.1 mm.

Dimensions of Reel

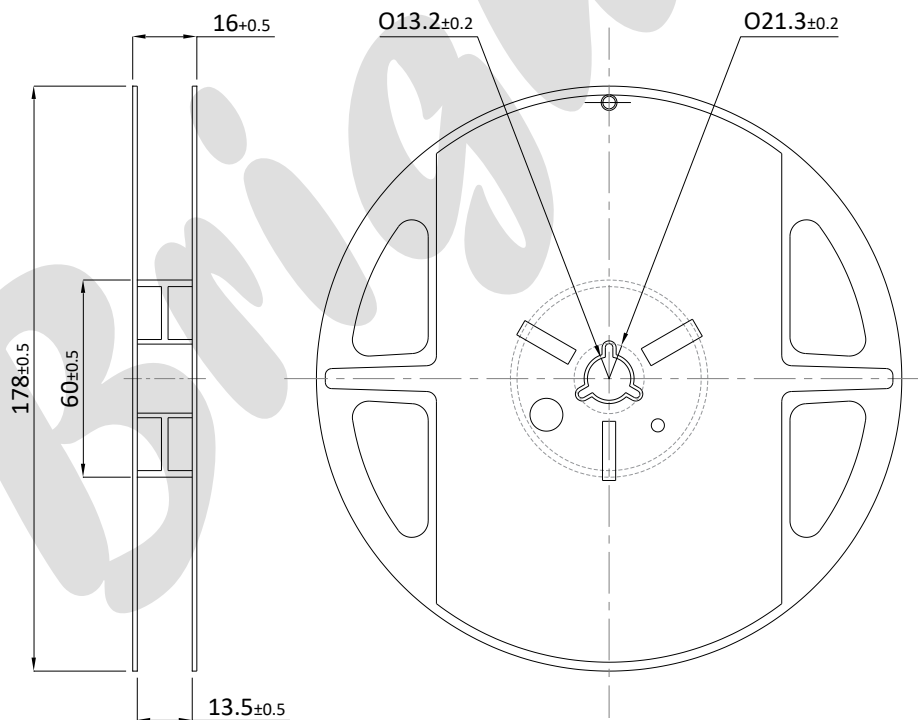

1. Dimensions are in millimeters.
2. 600 pieces per reel.
3. Dimensions acc. to EIA 481-E

SF3838F85CQ01

Barcode-Product-Label (BPL)

	MSL
Part No:	
O Item:	
N Item:	
Q'TY:	
VF:	(mA)
IV:	(mA)
WL:	(mA)
Lot No:	
XXXX-XXXX XXXX / PLSTXXXX	RoHS PASS

- Part No : Product Number
- O Item : Customer's Product Number
- N Item : Product Name
- Q'TY : Packing Quantity
- VF : Voltage Rank
- IV : Luminous Intensity Rank
- WL : Wavelength Rank
- Lot No : Lot Number
- MSL : MSL Level
- XXXX-XXXX XXXX / PLSTXXXX : Identify Label Number

Dry Packing Process and Materials

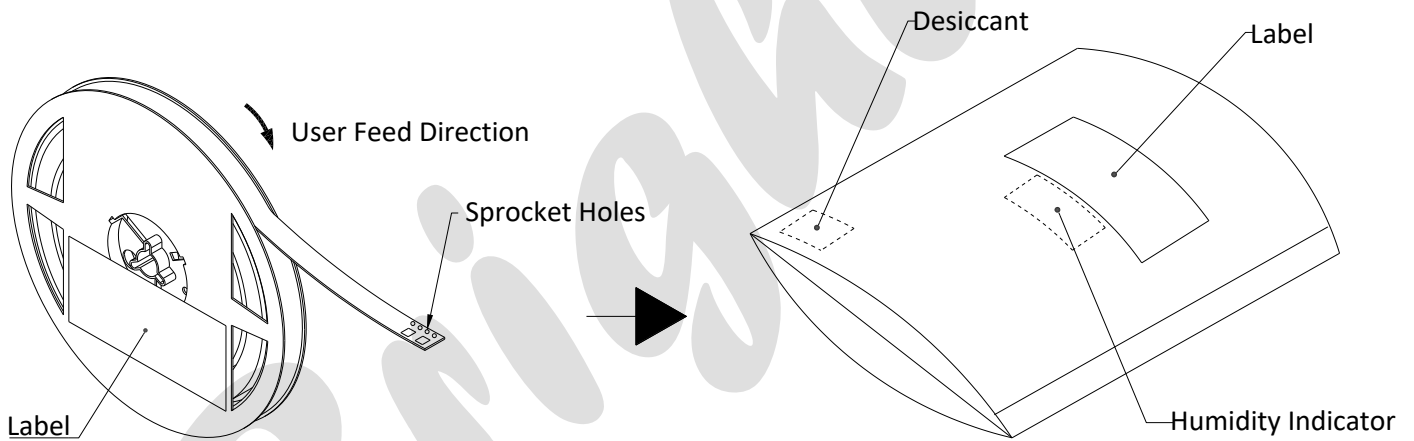

1. Moisture-sensitive product is packed in a dry bag containing desiccant and a humidity card according JEDEC-STD-033.

Disclaimer

1. Brightek reserves the right(s) on the adjustment of product material mix for the specification.
2. The product meets Brightek published specification for a period of one year from date of shipment.
3. The graphs shown in this datasheet are representing typical data only and do not show guaranteed values.
4. When using this product, please observe the absolute maximum ratings and the instructions for using outlined in these specification sheets. Brightek assumes no responsibility for any damage resulting from the use of the product which does not comply with the absolute maximum ratings and the instructions included in these specification sheets.
5. These specification sheets include materials protected under copyright of Brightek. Reproduction in any form is prohibited without obtaining Brightek's prior consent.
6. This product is not intended to be used for military, aircraft, life sustaining or life saving applications or any other application which can result in human injury or death. Please contact authorized Brightek sales agent for special application request.